

**EMB S.r.l**Via degli artigiani,8
26014 - Romanengo (CR)

TIPO/TYPE:	BTT381302301
MOTORE N.°/MOTOR N.°	20-17
Codice/code	711083
Serie:	Standard

DESCRIZIONE/DESCRIPTION:

- Triplo stadio/Triple stage
- 230 V. 50/60 Hz.
- Classe di isolamento I /Insulating class I
- Classe di temperatura F /Temperature class F
- 2 cuscinetti/Double ball bearings
- 1 velocità/ Single speed
- By Pass scarico tangenziale/Tangential bypass discharge
- Ponticello Alluminio/Aluminium bridge commutator side

Test Date:	07/02/2017
Hours:	17:30
Room Temp:	20,9°C
RH:	29,0%
Absolute Bar Press.:	1005

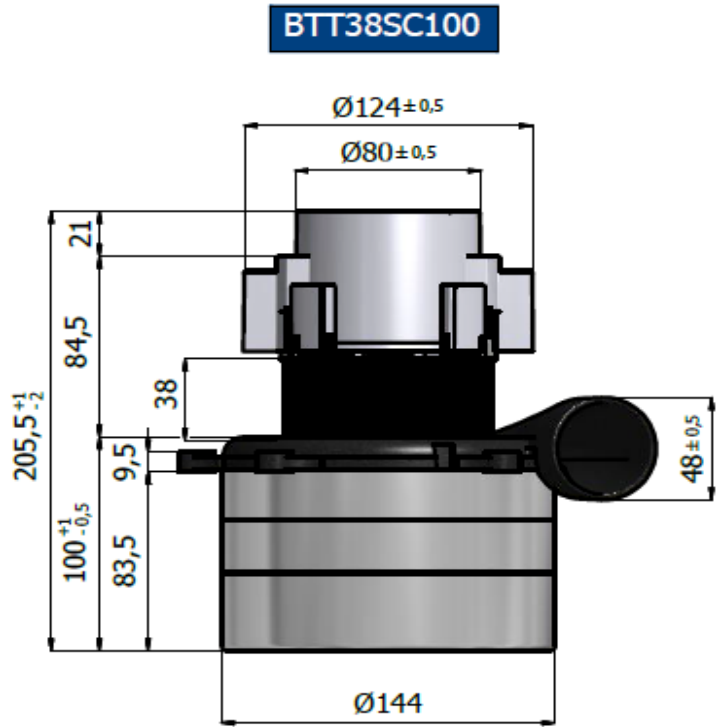

**CARATTERISTICA DI ASPIRAZIONE CON MOTORE APPLICATO SU CASSA DI MISURA
TYPICAL MOTOR PERFORMANCE ON MEASURING BOX**

Orifice mm	Current A	Input pow. W	Speed RPM	Vacuum/Depressure		Air Flow L/sec	Air Watts W	Efficiency %	Sound Level dB Max	Test Voltage :	230
				mm H ₂ O	mbars					Frequency :	50Hz.
48	6,06	1310	19030	69	6,8	37	25	1,9	83,0		
40	6,10	1310	18990	156	15,3	38	59	4,5	82,7	Nominal Power W.	1354
30	6,13	1330	18980	462	45,3	37	170	12,8	80,8	Middle Power W.	1151
23	6,13	1330	18870	958	93,9	31	292	22,0	79,9	Max. Power W.	1565
19	6,10	1330	18980	1378	135,1	25	344	25,9	79,8	Vacuum mmH ₂ O	3106
16	5,94	1290	19280	1705	167,2	20	339	26,2	80,7	Air Flow L/s.	38,3
13	5,66	1250	19880	2015	197,5	14	283	22,6	85,2	Air Power W.	344
10	5,29	1160	20800	2308	226,3	9	213	18,4	82,3	Efficiency %	26,2
6,5	4,84	1070	21970	2663	261,1	4	98	9,2	82,2		
0	4,44	972	22550	3106	304,5	0	0	0,0	84,8		

